

Assembly Instructions

Double Tier One Wide Jorgenson Clear View Locker

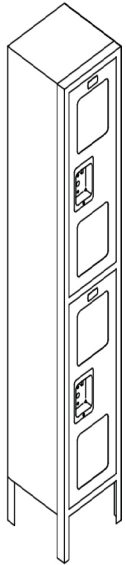

1

Identify Parts

Remove unassembled locker parts from the packaging. Next, locate and identify each part based on the images show below:

TIP: Tip: Ensure that the bolts are installed on the outside of locker and nuts are secured on the inside of the locker.

(1) Front Door (1) Back Panel (2) Side Panels

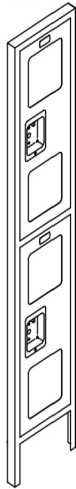

(3) Top/Bottom Panels

Top/Bottom are identical

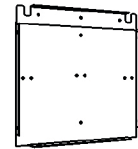

(2) Rear Legs

Legs are identical

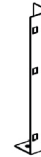

2

Start Assembling

- Position the back panel on a straight, even floor or a pair of sawhorses.
- Gently bolt the left and right side panels to the inside of the back panel.

Bolt the tamper-proof screw on the inside of the locker. Only the screw heads should be visible from the outside of the locker.

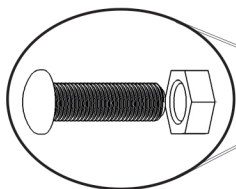

Left Side Panel

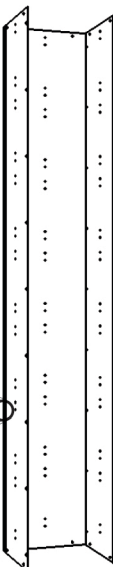

Top Holes are 1/2" from the top of each panel shown.

Right Side Panel

View of locker with back panel flat on floor or saw horses

The left and right side panels must be placed inside the back panel flanges.

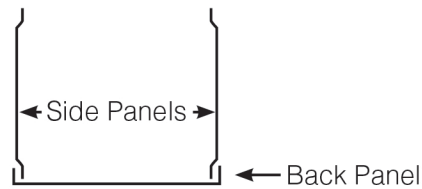

Assembly Instructions

Double Tier One Wide Jorgenson Clear View Locker

• 3 •

Continued Assembly

- Lightly bolt the top and bottom panels, as well as the legs, to the inside of the side and back panels

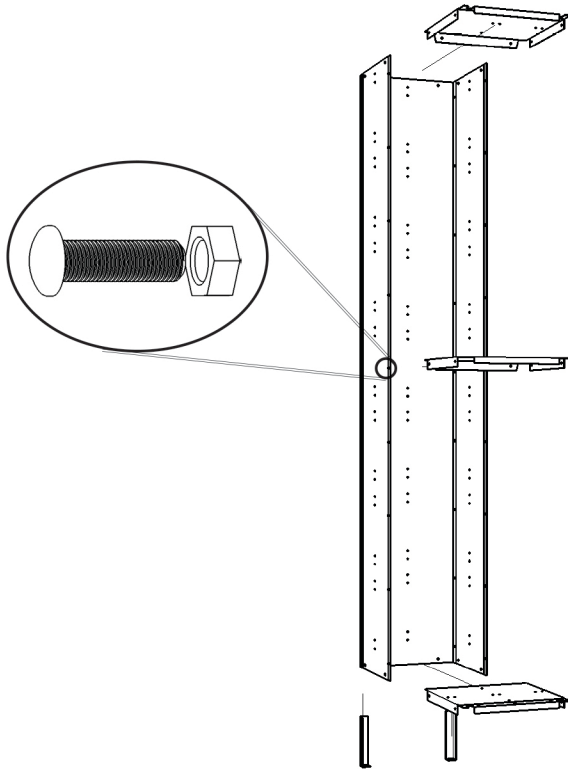

Note:

Top and bottom panels have two (2) round, pre-drilled holes that can be found on the back flange and are designed to bolt to the back panel.

The legs are now ready to be bolted. Place the locker in an upright position. The legs may require some adjusting to level the locker against the wall and floor.

• 4 •

Insert Front Door Frame

- After attaching the top and bottom panels, proceed to insert the door frame on the outside of the left, right, and bottom panels.

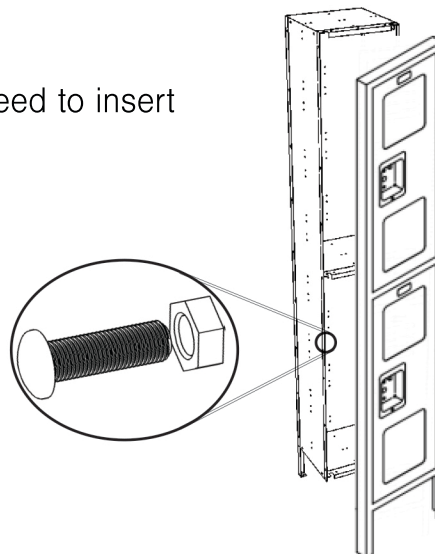

Assembly Instructions

Double Tier One Wide Jorgenson Clear View Locker

• 5 •

Insert Front Door Frame

- Place locker in the upright position and make sure locker is level, making any necessary adjustments with locker legs.
- When locker is level, test the door to determine it opens properly. Bolts can be adjusted if there are any problems with opening and closing.
- Once the door is functioning correctly, tighten all bolts.
- To instill proper safety measures, we highly advise anchoring the locker to the floor or wall to avoid injury or theft.

